



Leaders in Reception Seating

Lesro Industries, Inc.
1 Griffin Road South
Bloomfield, CT
06002

Phone
860.243.3226
Fax
860.243.5392
www.lesro.com

Assembly Instructions For Newport Ganging Bracket

Tools required: Phillips screwdriver, Allen wrench (included in hardware pack).

Note: These instructions are intended for various models and configurations. Your products may not look exactly as those shown in the diagrams.

Important: The assembly process requires that some hardware be kept loose until later in the sequence. Follow these instructions closely to ensure correct assembly.

Recommendation: Retighten all bolts on a seasonal basis to ensure your product remains strong and stable for many years of use.

Parts List

Ganging Brackets, 2 pcs.
5/8" Phillips Screws, 8 pcs.
Allen Wrench

1. Unpack and identify parts.
2. Assemble chairs individually according to chair instructions before attaching gang brackets.
3. Position chairs about 2 feet apart.
4. Use an Allen wrench to loosen the seat cushion bolts on facing sides of both chairs, as shown in figure 1.
5. Attach ganging brackets to one of the chairs. With bolt inserted fully into slot, as shown in figure 2, retighten bolts securely.
6. Pull the chairs together and attach the ganging brackets to the second chair, as shown in figure 3. Retighten these seat bolts securely.
7. With both chairs resting on a level floor, carefully align the back legs so they form a straight line.
8. Insert Phillips screws through brackets into bottom of seat cushions and tighten securely, using care not to strip.

If your ganged seating arrangement is only temporary, it is possible to connect the chairs without the Phillips screws. However, for stronger and more permanent installations, use of the Phillips screws is recommended.

9. Your product is now assembled and ready to use.

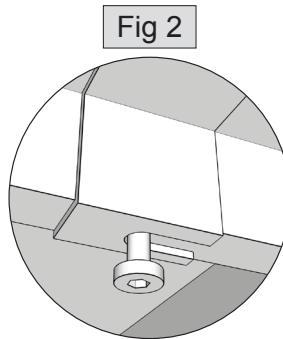
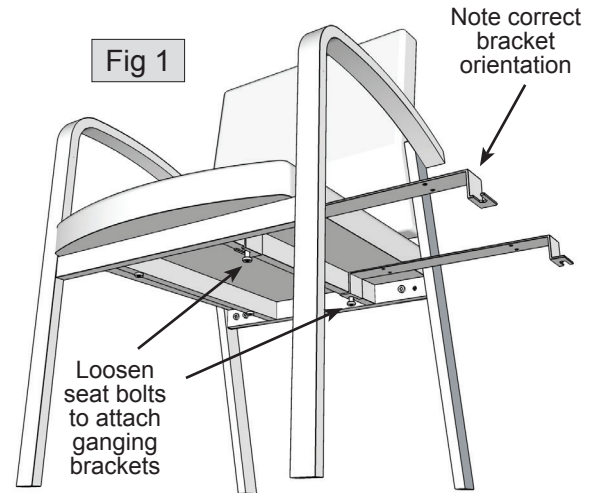
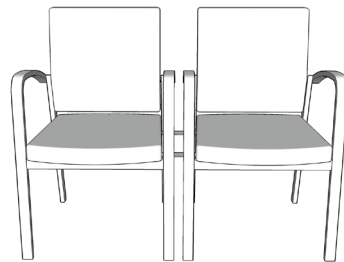

Bolt should be inserted fully into slot

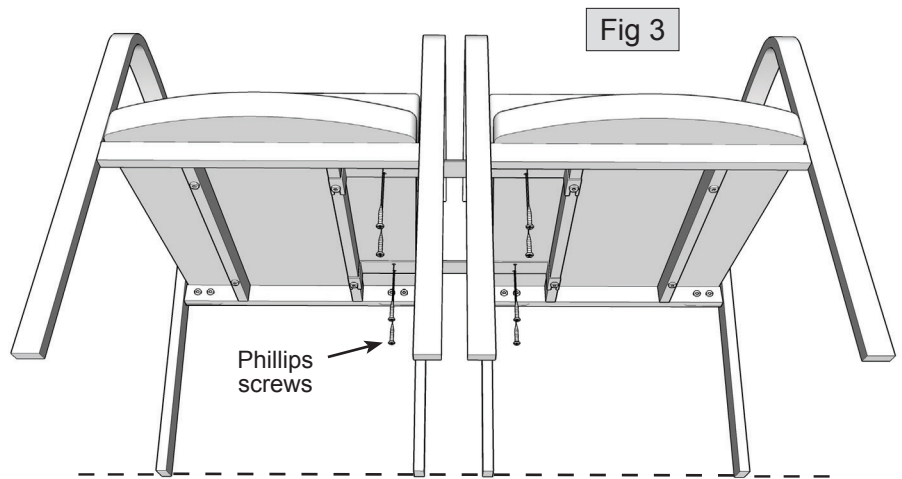

Be sure legs are in a straight line before inserting Phillips screws into bottom of seats

Thank you for purchasing a Lesro product.
Need assistance with assembly? Call Lesro customer service 1-800-275-7545.
Visit us online at www.lesro.com