



Leaders in Reception Seating

Lesro Industries, Inc.  
1 Griffin Road South  
Bloomfield, CT  
06002

Phone 860.243.3226  
Fax 860.243.5392  
www.lesro.com

# Assembly Instructions For Sheffield Connecting Corner Table

**Tools required:** Phillips screwdriver, Allen wrench (included in hardware pack).

**Note:** These instructions are intended for various models and configurations. Your product may not look exactly as shown in the diagrams.

**Important:** When moving table and chair assembly from one place to another, avoid putting excessive strain on connections or damage may occur. Use 2 or more people.

**Recommendation:** Retighten all bolts on a seasonal basis to ensure your product remains strong and stable for many years of use.

**Weight Capacity:** These tables are not intended for use as seats.

## Parts List

Tabletop  
Table Leg

## Hardware

Slotted Brackets, 4 pcs.  
3/4" Phillips Bolts, 4 pcs.  
3/4" Phillips Screws, 3 pcs.  
Allen Wrench

1. Unpack and identify all parts.
2. Assemble chairs individually before attaching table.
3. Place the tabletop upside down on a soft, clean surface to prevent scratching.
4. Attach leg to tabletop using Phillips screws through leg plate into pre-marked holes, as shown in figure 1. Tighten securely using care not to strip.
5. Attach slotted brackets to tabletop using bolts into threaded inserts also as shown in figure 1. Be sure brackets are flush with edge of tabletop. Keep bolts slightly loose for now.
6. Position chairs about 2 feet apart, oriented as shown in figure 2.
7. Using an Allen wrench, loosen the seat cushion bolts just enough that the heads stick out about 1/4" on facing sides of both chairs.
8. Set tabletop between chairs, as shown in figure 2. The slotted brackets should slide onto the bolts from step 7.
9. Press down on tabletop until bolts are fully inserted into each of the bracket slots. Be sure back leg of table is resting on the floor during this step. Tighten all bolts securely, including bracket bolts from step 5 and seat cushion bolts from step 7.
10. Your product is now assembled and ready to use.

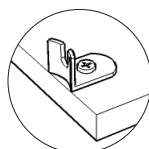
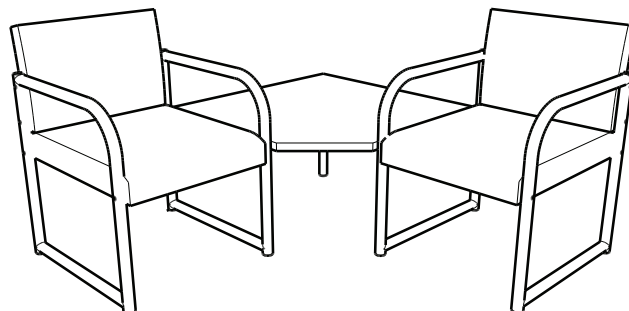

Brackets  
flush to edge

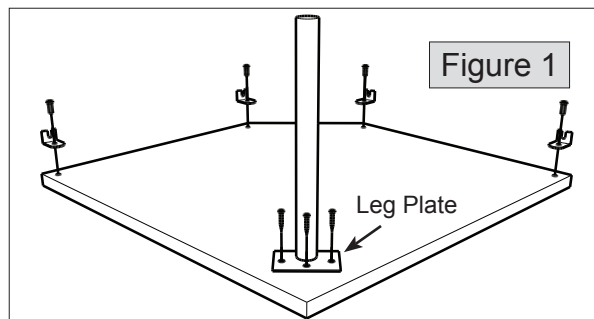
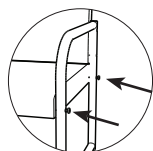

Figure 1



Loosen  
seat bolts

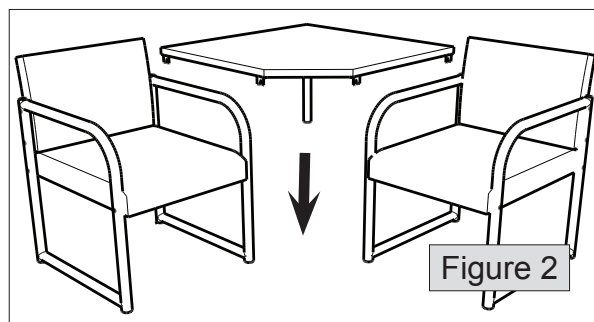

Figure 2

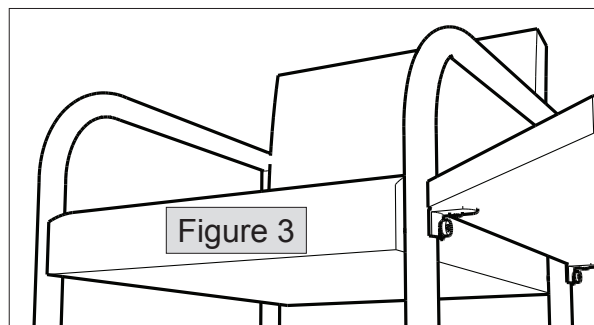

Figure 3

Thank you for purchasing a Lesro product.  
Need assistance with assembly? Call Lesro customer service 1-800-275-7545.  
Visit us online at [www.lesro.com](http://www.lesro.com)