



Leaders in Reception Seating

Lesro Industries, Inc.  
1 Griffin Road South  
Bloomfield, CT  
06002

Phone 860.243.3226  
Fax 860.243.5392  
www.lesro.com

# Assembly Instructions For Universal Ganging Bracket

**Tools required:** Phillips screwdriver.

**Note:** These instructions are intended for various models and configurations. Your products may not look exactly as those shown in the diagrams.

**Important:** The assembly process requires that some hardware be kept loose until later in the sequence. Follow these instructions closely to ensure correct assembly.

**Recommendation:** Retighten all bolts on a seasonal basis to ensure your product remains strong and stable for many years of use.

## Parts List

Ganging Brackets, 2 pcs.  
5/8" Phillips Screws, 8 pcs.

1. Unpack and identify all parts.
2. Fully assemble the chairs individually according to chair instructions before attaching gang brackets.
3. Lay one of the chairs gently on its back. Be sure to protect the back cushion from being damaged or soiled.
4. Position one of the brackets up against the rear leg and against the frame crossbar and attach to the bottom of the seat using Phillips screws, as shown in figures 1 and 2. Tighten screws securely. There are no predrilled holes.
5. Repeat step 4 with the second bracket up against the front leg.
6. Lay the second chair on its back and carefully pull the chairs into position as shown in figure 3.
7. With the brackets flush against the legs and the frame crossbar of the second chair, attach bracket to the bottom of the seat with Phillips screws, as shown in figure 4. Tighten securely.
8. Carefully return the 2 chairs to the upright position.
9. Your ganged chairs are now ready to use.

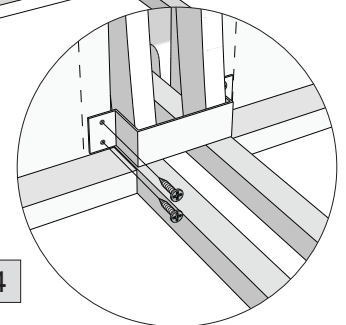
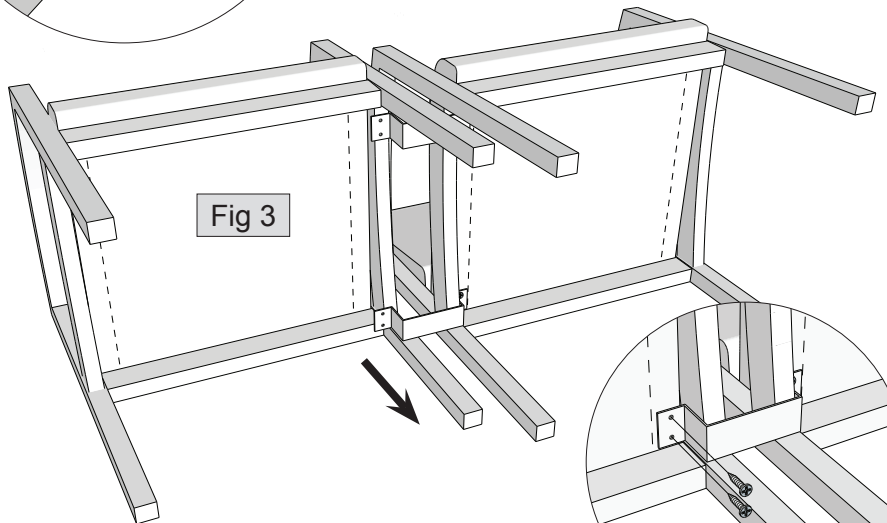
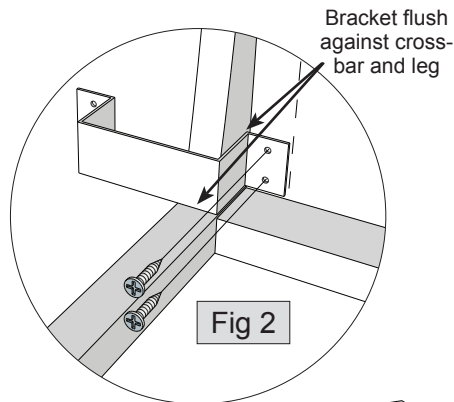
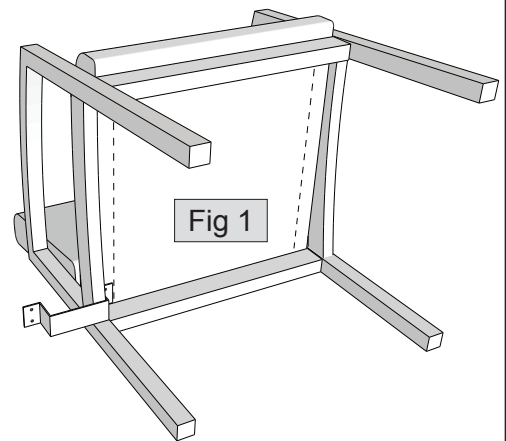
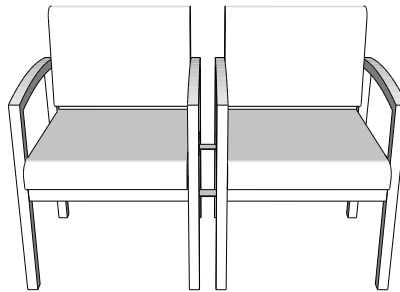

Thank you for purchasing a Lesro product.  
Need assistance with assembly? Call Lesro customer service 1-800-275-7545.  
Visit us online at [www.lesro.com](http://www.lesro.com)